

Montagevorgang zu Schutzglasring D95 IP54

Assembly procedure for protective glass ring D95 IP54

Procédure de montage de la bague de protection en verre D95 IP54

Procedura di montaggio dell'anello di protezione in vetro D95 IP54

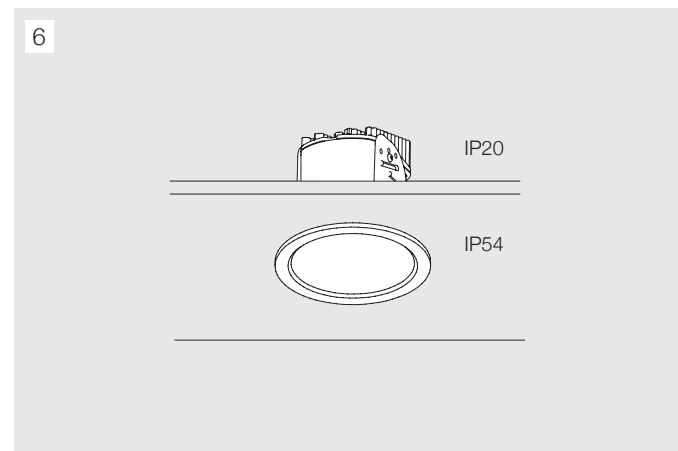
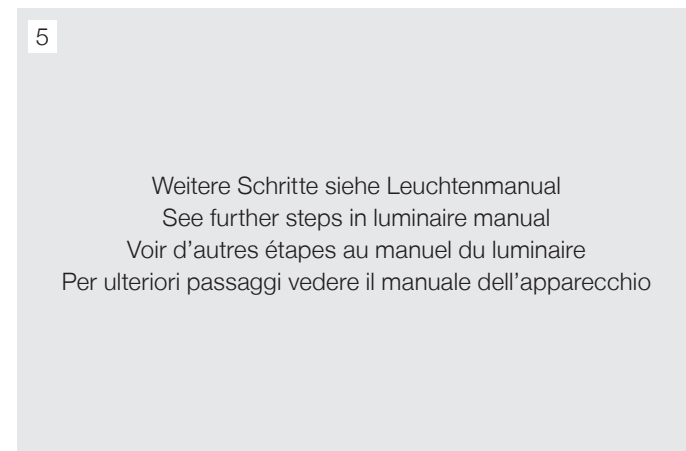
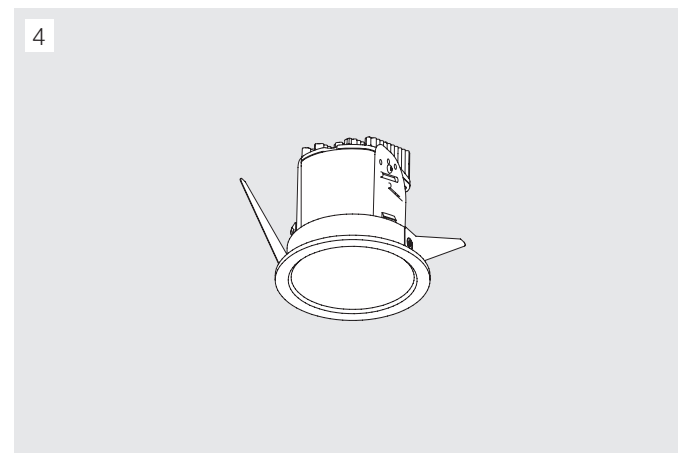
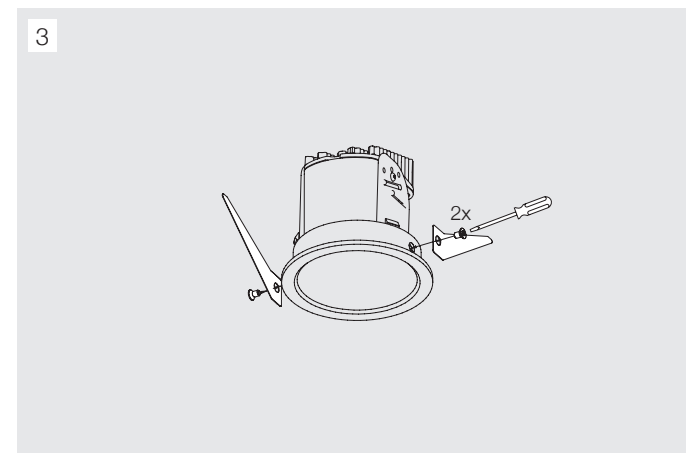
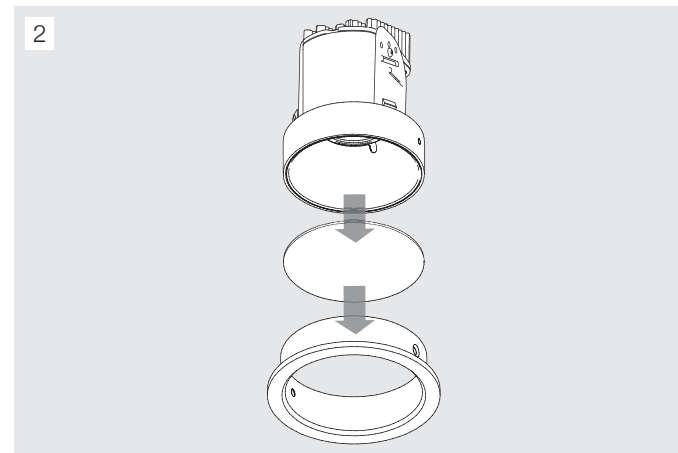
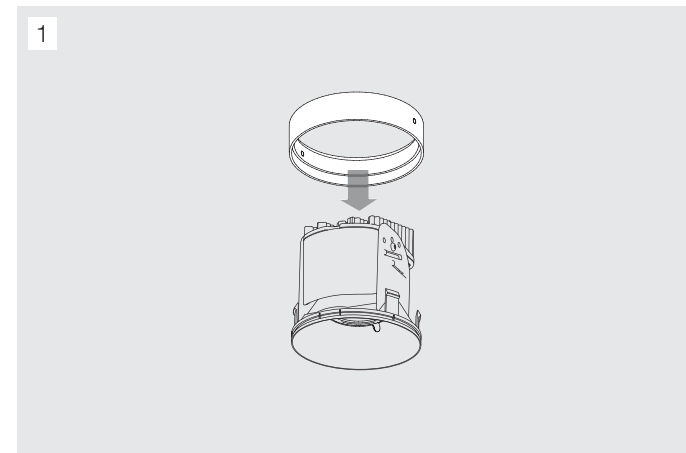

Montagevorgang zu Schutzglasring D95 IP54

Assembly procedure for protective glass ring D95 IP54

Procédure de montage de la bague de protection en verre D95 IP54

Procedura di montaggio dell'anello di protezione in vetro D95 IP54

IP54

DE Von unten bei geschlossener Decke: Schutz gegen Staub in schädigender Menge und Strahlwasser aus allen Richtungen.

EN From below, by closed ceilings: Protection against dust in damaging amount and jet water from all directions.

FR Par le bas, avec plafond fermé: Protection contre la poussière en quantité nuisible et jet d'eau de tous les directions.

IT Dal basso con il soffitto chiuso: protezione dalla polvere in quantità dannose e getti d'acqua da tutte le direzioni.



DE Nur für den Gebrauch in Innenräumen.

EN This product is designed for indoor use only.

FR Ce produit est conçu uniquement pour une utilisation intérieure.

IT L'apparecchio è previsto solo per uso interno.



DE Leuchte darf nur nach unten strahlend eingebaut werden.

EN Luminaire must be installed facing downwards.

FR Le luminaire ne doit pas être directement recouvert de matériaux isolants.

IT Il proiettore non deve essere coperto direttamente da materiale coibentante.

IP20

DE Von unten bei geschlossener Decke: Schutz gegen Staub in schädigender Menge und Strahlwasser aus allen Richtungen.

EN From below, by closed ceilings: Protection against dust in damaging amount and jet water from all directions.

FR Par le bas, avec plafond fermé: Protection contre la poussière en quantité nuisible et jet d'eau de tous les directions.

IT Dal basso con il soffitto chiuso: protezione dalla polvere in quantità dannose e getti d'acqua da tutte le direzioni.



DE Nicht über den Hausmüll entsorgen, sondern ordnungsgemäss dem Recycling zuführen.

EN Do not dispose as household waste, but make the proper recycling.

FR Ne doit pas être jeté dans la poubelle, veuillez utiliser un centre de recyclage approprié.

IT Non gettare nei rifiuti domestici, ma effettuare il corretto riciclaggio.

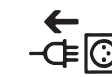

DE Leuchte spannungslos schalten.

EN Disconnect lamp from the power supply.

FR Brancher les luminaires hors tension.

IT Accendere l'apparecchio in assenza di tensione.